

## ELECTRIC CHAIN HOIST

### FEATURES:

Employs imported FEC80 class high strength heat treated alloy steel chain.

### LIMIT SWITCH POSITIONS:

Limit switches are provided at lift-up and down stroke to prevent poor smoothness of chain or loosening while ensuring safety.

### PENDANT CONTROL

24 Volt Low Voltage

10 metres of cable on pendant with up/down and emergency stop

Specially designed fail-safe dual disc DC magnetic brakes

Electronic overload protector and emergency stop switch

In case of power failure, the fail-safe brake is activated immediately



MODEL		CH35-1110
Capacity (KG)		1000
Lift (M)		6
Hoisting Speed (M/min)	50HZ	5
	60HZ	6.1
Hoisting Motor (KW)		0.75
Chain Dia x Pitch		FEC Ø7.1X21 PITCH
Chan Falls Line		1
Power Source		1PH 220~240V
Approx. Weight (KG)		35
Approx. Dimensions (mm)	A	235
	B	119
	C	460
	D	246
	E	520
	F	31
	G	42.5
	H	85
	I	31
	J	20
	B1	116
D1	214	

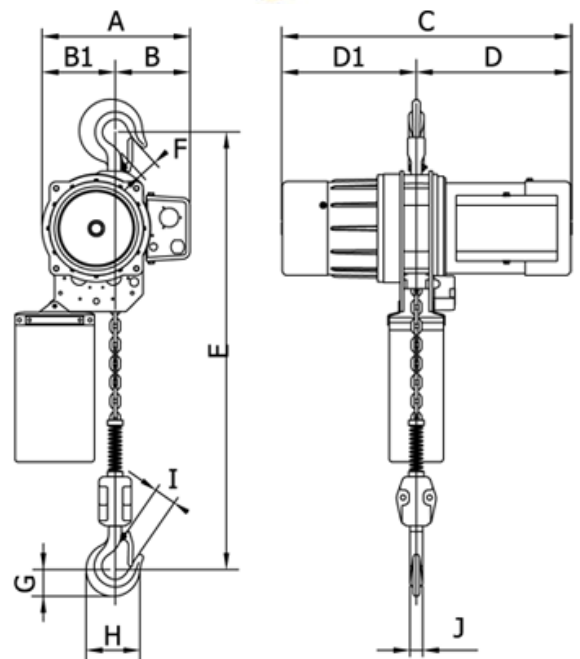

PRODUCT SPECIFICATIONS AND FEATURES ARE SUBJECT TO CHANGE AS A RESULT OF TECHNOLOGICAL PROGRESS WITHOUT PRIOR NOTICE. THREE PHASE MOTOR IS AVAILABLE.

Email: [admin@winch.com.au](mailto:admin@winch.com.au) Website: [www.winch.com.au](http://www.winch.com.au)

Phone: 07 3875 1568

Address: 2 Coin Street Moorooka Qld 4105 Postal: PO Box 206 Acacia Ridge Qld 4110