

JV SERIES

The Tiger JV series winches are of planetary design, compact and engineered to exacting standards. Built with a precision and efficient three stage planetary gear box, quality roller bearings feature throughout.

An independent electromagnetic failsafe multi disc brake provides safe, easy load control. The JV Series Tiger winch features, as all Tiger Winches do a low voltage safety control system, 10 metre push button pendant control with Emergency Stop as standard.



BUILT TO COMPLY TO AUSTRALIAN STANDARDS

APPLICATIONS

- These are capable of an endless range of applications
- Hauling - including use as a boat ramp winch
- General lifting
- Lifting sullage pumps
- Use in Agricultural environments, water pump installation etc.

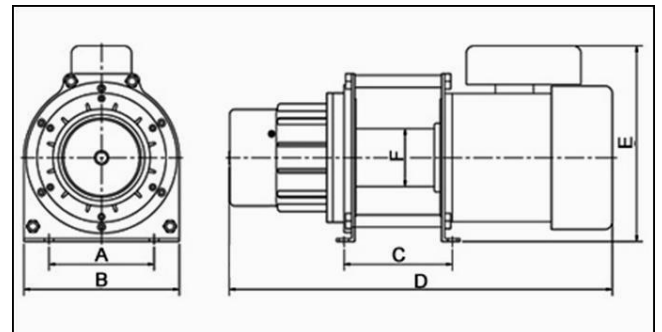

STANDARD FEATURES

- 240V Motor – They are designed with maximum torque in mind.
- They have huge duty cycles and are built to be incredibly reliable.
- Special expertise is used in the design and manufacture of these motors to suit craning and winch applications.
- Pre-wired for 240V Single Phase with 3 pin 10 AMP plug.
- Wire rope with safety hook.
- Low voltage push button pendant control with 10m lead every- thing you need to bolt it down and ready for operational use immediately.
- Optional wireless remote control available

MODEL		250KG		300KG	
		JV-1025-13D03		JV-1030-13D03	
Steel Rope		6mm x 30m		6mm x 30mm	
Speed (m/min)	50HZ	11		11	
Voltage		1PH 220~240V			
Motor (KW)		0.55		0.75	
Body Dimensions (mm)		A	142	142	
		B	210	210	
		C	142	142	
		D	486	527	
		E	265	265	
		F	78	78	
N.W. (KG)		31.6		31.6	
G.W. (KG)		33.0		33.0	

Email: admin@winch.com.au **Website:** www.winch.com.au

Phone: 07 3875 1568

Address: 2 Coin Street Moorooka Qld 4105 **Postal:** PO Box 206 Acacia Ridge Qld 4110

This may save a life or at the very least you might find this interesting!

We have been selling and servicing Tiger Winches for more than 15 years, they are incredibly durable, safe and fantastic value for money. Your Tiger Winch is fitted with a multi disc brake system which is second to none.

Whichever Tiger Winch model you make yours they all incorporate a safety 24 Volt Pendant Control system with 10 metres of pendant control wire complete with an emergency stop button.

What does all this mean to you and your family?

It means you can have absolute confidence and peace of mind when using your winch, if for any reason the power is shorted out or the supply interrupted, or if you have to leave your winching operation for any reason the brakes are applied immediately. You can be assured the multi disc brake safety system will absolutely stop and hold your load.

We have hundreds of these beaut, tough little units in service in some of the most severe circumstances, for example where they are close to water such as pontoons etc. This is where the low voltage controller comes into its own, let's say the controller gets broken and the internal wires are exposed or it is submerged in water, a tingle is all you will receive.

The controller being low voltage 24 Volt power – not 240 or 415 Volt - cannot "hurt" you. Your Boat Ramp Winch is one of the very few to offer this safety system on 240V as well as 415V winches.

For that little added safety and security, the pendant on your new Winch has a quick disconnect system so when your winch is not in use, no one else can tamper with it.

WIRELESS REMOTE SYSTEM

Please check out this brilliant option. Your Boat Ramp Winch is so easy to use with this simple option. The best news of all is, as far as we know your Winch is one of the only winches that offer a completely wireless system whilst retaining your pendant control at the same time. This is fantastic news, if a flat battery may occur in your wireless system, you will still have backup. If a 24V pendant controller is broken, you will still have the wireless opportunity.

Email: admin@winch.com.au **Website:** www.winch.com.au

Phone: 07 3875 1568

Address: 2 Coin Street Moorooka Qld 4105 **Postal:** PO Box 206 Acacia Ridge Qld 4110

MAXIMUM BOAT MASS*

OUR BOAT RAMP WINCH MODELS	LIFTING CAPACITY	HAULING CAPACITY SLOPE RAMP GRADIENT				
		ROPE LENGTH	5° BOAT RAMP 1m FALL OVER 12m DISTANCE (KG)	12.5° STANDARD BOAT RAMP 1m FALL OVER 4.5m DISTANCE (KG)	15° BOAT RAMP 1m FALL OVER 3.75m DISTANCE (KG)	27° BOAT RAMP 1m FALL OVER 2m DISTANCE (KG)
TIGER SERIES	SIZE (KG)					
PLANETARY GEAR DRIVE						
JV-1025-13D03		6mm x 30m				
JC-1025-16D05	250	6mm x 50m	2,750	1,100	950	500
JC-1025-17D12		6mm x 120m				
JV-1030-13D03		6mm x 30m				
JC-1030-16D05	300	6mm x 50m	3,250	1,300	1,100	650
JC-1050-16F03		8mm x 30m				
JC-1050-21F05	500	8mm x 50m	5,000	2,100	1,800	1,100
RC-1050-21F10		8mm x 100m				
PU-1070-09G07	700	9mm x 70m	7,000	3,000	2,500	1,500
PU-1100-05H06	1000	10mm x 60m	10,000	4,200	3,600	2,200
PU-1120-10I05	1200	12mm x 50m	12,000	5,000	4,300	2,650
PU-1200-07J07	2000	14mm x 70m	20,000	8,400	7,200	4,400
BLUE SERIES						
SPUR GEAR DESIGN						
AM1026B SS	N/A	8mm x 30m	8,000	3,600	3,000	1,800
AM2026B	N/A	10mm x 30m	15,000	7,000	5,750	3,600
G&W SERIES						
STAINLESS STEEL						
G&W 2500	N/A	8mm x 30m	6,250	2,500	2,300	1,350
G&W 3500	N/A	8mm x 30m	7,800	3,500	2,900	1,700
G&W 4500	N/A	9mm x 30m	11,000	4,500	3,900	2,500
G&W 5500	N/A	10mm x 30m	13,000	5,500	4,750	2,850

SOME OF THESE OPTIONS AVAILABLE INCLUDE:

DYNEEMA ROPE, STANDS, COVERS AND RADIO REMOTE AVAILABLE ON ALL MODELS

BIGGER MODELS AVAILABLE ON REQUEST

Email: admin@winch.com.au **Website:** www.winch.com.au

Phone: 07 3875 1568

Address: 2 Coin Street Moorooka Qld 4105 **Postal:** PO Box 206 Acacia Ridge Qld 4110

BLUE SERIES

This heavy-duty model boasts all solid steel construction with precision hob cut gears. These features all contribute to a product range that is incredibly reliable, efficient, strong and durable. All models can be fitted with remote controls. Suitable for hauling up to 7000kg.



**AM1026B SS WINCH
(THIS MODEL IS CONSTRUCTED
IN 316 STAINLESS STEEL)**

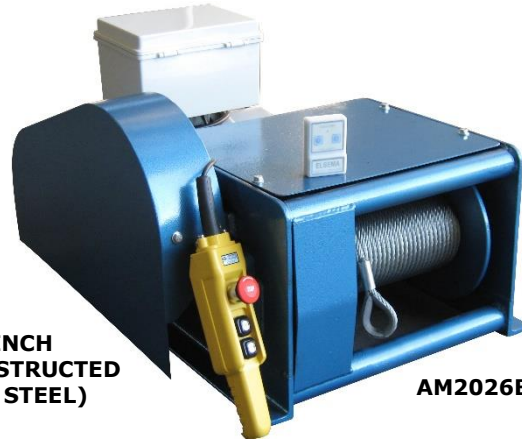

AM2026B WINCH



TIGER SERIES

Our unique tough range of Tiger winches are of the planetary design, rugged in construction and engineered to exacting standards. The tiger is light weight yet strong. All models fitted with fail safe brakes and low voltage pendant control with 10 meters of cable. Models to suit tinnies and up.

G&W SERIES

We manufacture these in our factory in Brisbane, we will happily modify these winches to suit your individual needs. They are manufactured with stainless side mounts, bearing carriers, cover and cross bars. There's a full cover option for outdoor use.

Driven by a self-braking worm gear transmission providing a quiet, safe, maintenance free operation coupled to a purpose built powerful 240V or 415V electric brake motor.

**SOME OF THESE OPTIONS AVAILABLE INCLUDE:
DYNEEMA ROPE, STANDS, COVERS AND RADIO REMOTE
AVAILABLE ON ALL MODELS**

BIGGER MODELS AVAILABLE ON REQUEST



**G&W 3500 WINCH
(THIS MODEL IS CONSTRUCTED
IN 316 STAINLESS STEEL)**

Email: admin@winch.com.au **Website:** www.winch.com.au

Phone: 07 3875 1568

Address: 2 Coin Street Moorooka Qld 4105 **Postal:** PO Box 206 Acacia Ridge Qld 4110