

TIGER ELECTRIC WINCHES SERIES F PARTS LIST

Tiger winch range spare parts diagram

When ordering replacement parts, please check the box against your winch Model Number and the Item No's required and write the total quantity of the parts required in the table below.

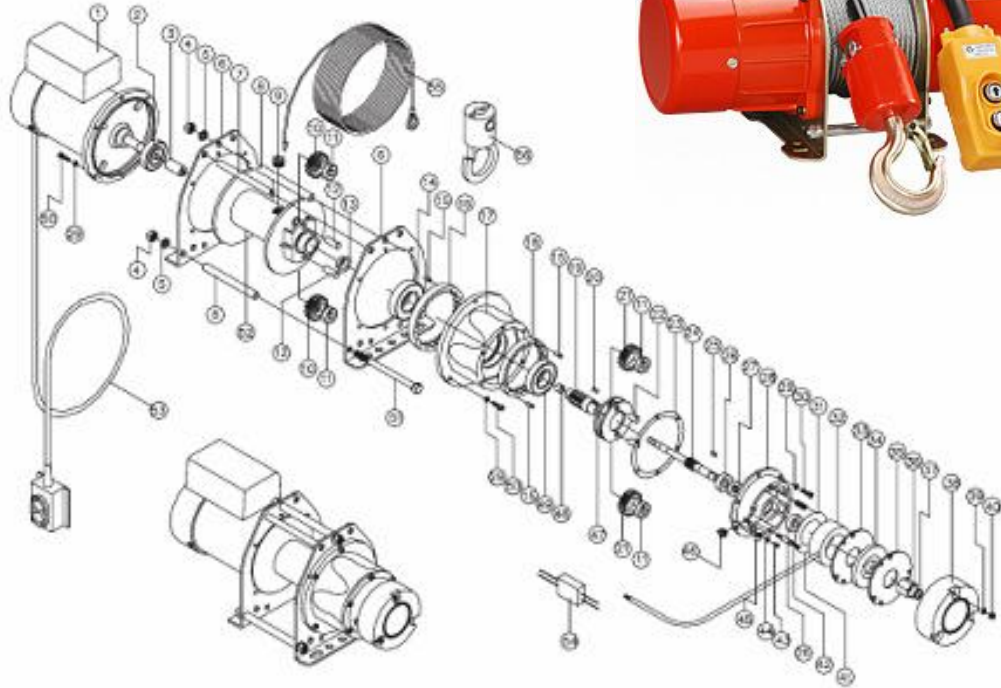

Spares are for

Model No.

FO5-20

FO5-25

FO6-30

FO7-50

FO8-50

Item	Description	Qty	Spares		Item	Description	Qty	Spares		Item	Description	Qty	Spares	
			Req	Qty				Req	Qty				Req	Qty
1	Motor	1			20	Key	1			39	Washer	3		
2	Bearing	1			21	Gear Pinion	2			40	Hex Nut	3		
3	Sleeve	1			22	Shaft	2			41	Insulation Card	1		
4	Hex Nut	3			23	Spacer	1			42	Brake Screw	3		
5	Spring Washer	3			24	1st Shaft Assy	1			43	Pan Head Screw	2		
6	End Support	2			25	Key	1			44	Washer	2		
7	Tie Bar	1			26	Bearing	2			45	Grommet	2		
8	Sleeve	3			27	Oil Seal	1			46	Wire Clip	1		
9	Grub Screw	1			28	Conductor	1			47	Carrier	1		
10	Bull Gear	2			29	Spring Washer	18			48	Bush	1		
11	Bearing	4			30	Cap Screw	6			49	Bearing	1		
12	Shaft	2			31	Spring	3			50	Cap Screw	12		
13	Sleeve	1			32	Brake Coil	1			51	Screw	3		
14	Bearing	1			33	Brake Disc	1			52	Drum	1		
15	Hollow Pin	4			34	Brake Lining	1			53	Control Cable	1		
16	Ring Gear	1			35	Brake Disc	1			54	Rectifier	1		
17	Gear Housing	1			36	Socket Assembly	1			55	Wire Rope	1		
18	Ring Gear	1			37	C-Ring	1			56	Hook			
19	2nd Shaft Assy	1			38	Brake Cover	1			57				

Your Winch Industries Distributor is:



Winch Industries Pty Ltd
2 Coin Street
Moorooka Qld 4105
PO Box 206
Acacia Ridge Qld 4110
Ph: (07) 3875 1568
Fx: (07) 3277 4316
www.winch.com.au