

# TIGER ELECTRIC WINCH J SERIES

Tiger range of winches are all of planetary design, rugged in construction and engineered to exacting standards. Built with a precision two stage planetary gear box, they feature quality roller bearings throughout. The winch is supplied with a high starting torque motor, designed and manufactured specifically for hauling and hoisting applications. An independent electro magnetic failsafe disc brake provides safe, easy load control. The new and improved J Series Tiger features a low voltage 10 metre push button pendant control with E Stop as standard.

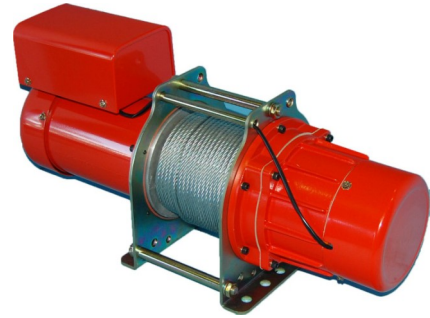

## Applications

- Boat ramp winch
- General lifting
- Positioning caravans or large trailers in confined areas
- Lifting sullage pumps
- Agricultural environments, water pump installation and removal

## J Series Standard Features

Pre-wired for 240V Single Phase with a standard 3 pin plug  
 Supplied with wire rope and safety hook  
 Low voltage push button pendant control with 10m lead

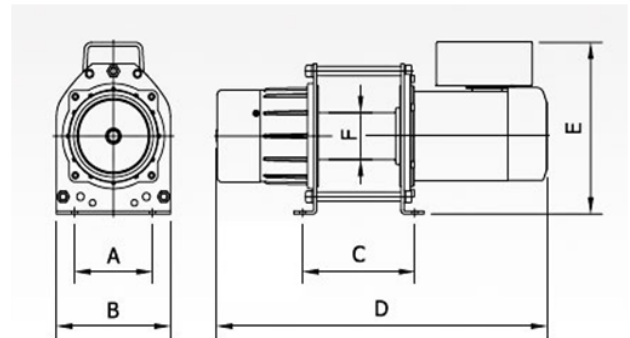

	JV-1020-13D03	JV-1025-13D03	JV-1030-13D03	JC-1025-16D05	JC-1025-17D12	JC-1030-16D05
Lifting Capacity	200KG	250KG	300KG	250KG	250KG	300KG
Av. speed (m/min)	50HZ 11	11	11	13	14	13
Wire Rope	6mm x 30M	6mm x 30M	6mm x 30M	6mm x 50M	6mm x 120M	6mm x 50M
Voltage	1PH 240V					
Motor( Kw)	0.50	0.55	0.75	0.75	1.1	1.1
Body dimensions (mm)	A	142	142	142	161.3	161.3
	B	210	210	210	220	220
	C	142	142	142	186	186
	D	474	486	527	556	666
	E	265	265	265	280	280
NW (KG)	29.7	30.2	33.6	34.5	56.5	38.3

Your Winch Industries Distributor is:



## GEARS AND WINCHES

A registered trading name of  
 Winch Industries Pty Ltd  
 2 Coin Street  
 Moorooka Qld 4105  
 Ph: (07) 3875 1568  
 Fx: (07) 3277 4316  
[www.winch.com.au](http://www.winch.com.au)